

SiC MOSFET
SiC N-Channel Planar Power MOSFET
General Features

- $V_{DS}=1200V, I_D=74A$
- Low ON Resistance, $R_{DS(ON)}=40m\Omega @ V_{GS}=18V, I_D=40A$
- Wide bandgap SiC MOSFET technology
- Low On-Resistance with High Blocking Voltage
- Low Capacitances with High-Speed switching
- Low reverse recovery(Qrr)
- Halogen free, RoHs compliant

Benefits

- Reduce switching losses
- Increased system Switching Frequency
- Increased power density
- Reduction of heat sink requirements

Application

- Switch mode power supplies
- Renewable energy
- Motor drives
- High voltage DC/DC converters

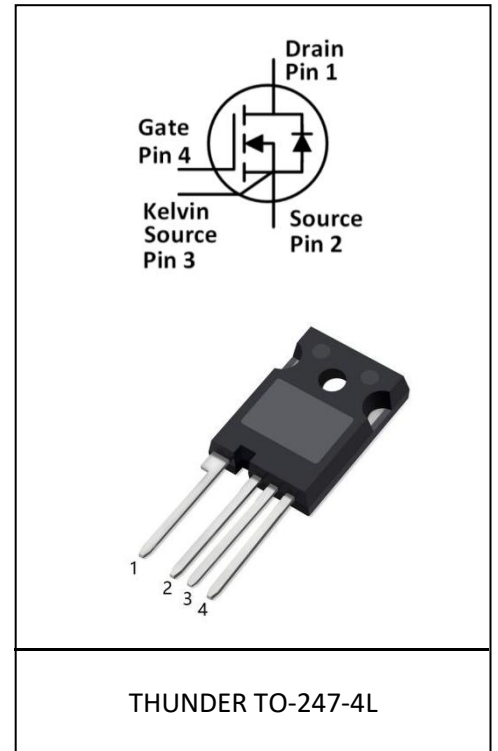
Product Summary

V_{DS}	1200V
$R_{DS(on)}$	40m Ω
I_D	74A

Absolute Maximum Ratings

Parameter	Symbol	Value	Unit
Drain-source voltage	V_{DS}	1200	V
Continuous drain current $T_C = 25^\circ C$ $T_C = 100^\circ C$	I_D^*	74 53	A
Pulsed drain current ($T_C = 25^\circ C$, t_p limited by T_{jmax})	I_{DM}^*	150	A
Gate-Source voltage	V_{GSmax}	-8/+22	V
Recommend Gate-Source Voltage	V_{GSop}	-4/+18	V
Operating junction and storage temperature	T_j, T_{stg}	-40...+175	$^\circ C$

* Verified by design

Electrical Characteristic (at $T_j = 25\text{ }^\circ\text{C}$, unless otherwise specified)

Parameter	Symbol	Value			Unit	Test Condition
		min.	typ.	max.		

Static Characteristic

Drain-source breakdown voltage	BV_{DSS}	1200	-	-	V	$I_D=100\mu\text{A}, V_{GS}=0\text{V}$
Gate threshold voltage	$V_{GS(th)}$	2	2.6 2.0	4	V	$V_{DS}=V_{GS}, I_D=10\text{mA}$ $T_j=25\text{ }^\circ\text{C}$ $T_j=175\text{ }^\circ\text{C}$
Zero gate voltage drain current	I_{DSS}	-	1	-	μA	$V_{DS}=1200\text{V}, V_{GS}=0\text{V}$
Gate-source leakage current	I_{GSS}	-	-	250	nA	$V_{DS}=0\text{V}, V_{GS}=18\text{V}$
Drain-source on-state resistance	$R_{DS(on)}$	-	40 47	-	m Ω	$V_{GS}=18\text{V}, I_D=40\text{A}$ $T_j=25\text{ }^\circ\text{C}$ $T_j=175\text{ }^\circ\text{C}$

Dynamic Characteristic

Input Capacitance	C_{iss}	-	2968	-	pF	$V_{DS}=1000\text{V},$ $f=100\text{KHz},$ $V_{GS}=0\text{V}$
Output Capacitance	C_{oss}	-	119	-		
Reverse Transfer Capacitance	C_{rss}	-	12	-		
Gate Total Charge	Q_g	-	117	-	nC	$V_{DS}=800\text{V},$ $I_D=40\text{A},$ $V_{GS}=-4/18\text{V}$
Gate-Source charge	Q_{gs}	-	38	-		
Gate-Drain charge	Q_{gd}	-	27	-		

Body Diode Characteristic

Parameter	Symbol	Value			Unit	Test Condition
		min.	typ.	max.		
Body Diode Forward Voltage	V_{SD}	-	5.0 4.5	-	V	$V_{GS} = -4V, I_{SD} = 20A$ $T_j = 25^\circ C$ $T_j = 175^\circ C$
Body Diode Continuous Forward Current	I_S	-	45 20	-	A	$V_{GS} = -4V$ $T_C = 25^\circ C$ $T_C = 100^\circ C$
Body Diode Reverse Recovery Time	t_{rr}	-	19	-	ns	$V_{GS} = -4V, I_{SD} = 40A,$ $V_R = 800V,$ $di/dt = 3900A/us$
Body Diode Reverse Recovery Charge	Q_{rr}	-	500	-	μC	
Peak Reverse Recovery Current	I_{rm}		50		A	

Typical Performance

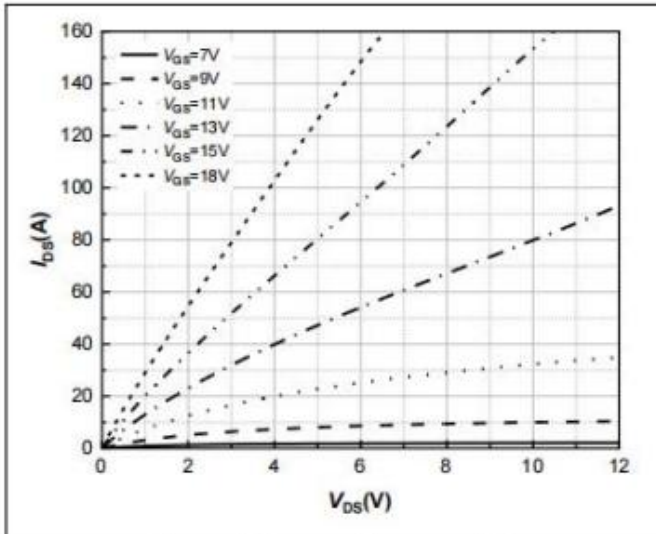

Figure 1. Output Characteristics
 $T_j = -40^\circ\text{C}$

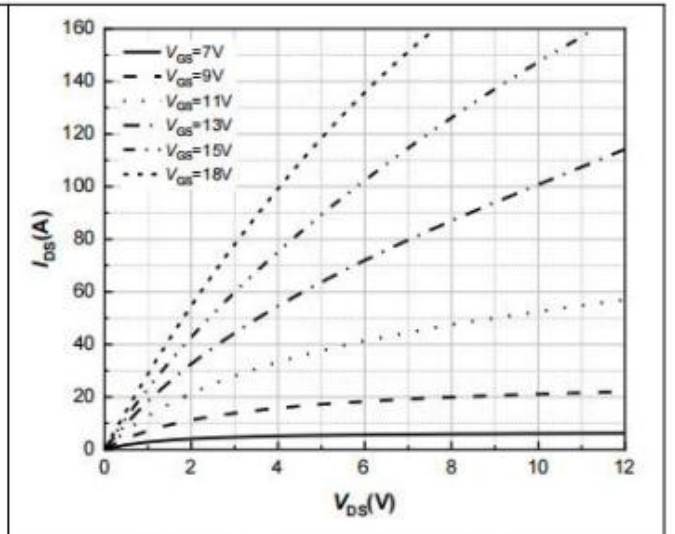

Figure 2. Output Characteristics
 $T_j = 25^\circ\text{C}$

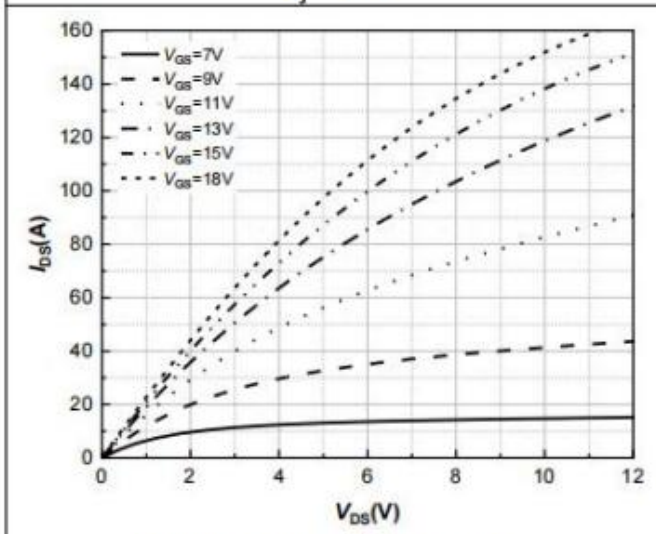

Figure 3. Output Characteristics
 $T_j = 175^\circ\text{C}$

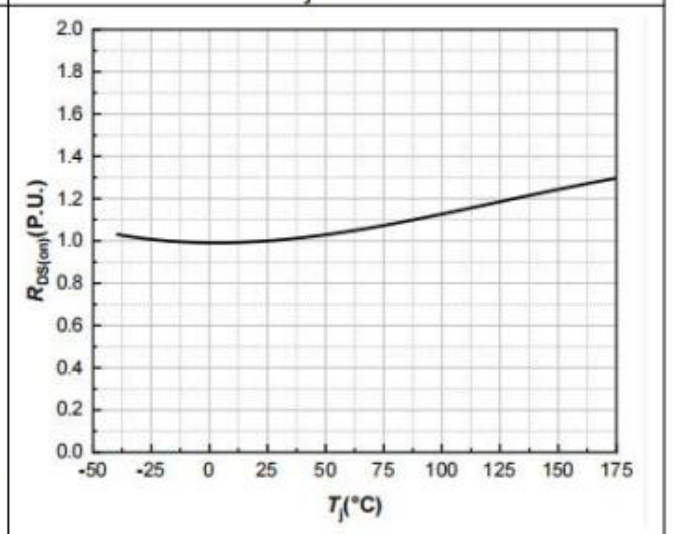

Figure 4. Normalized On-Resistance vs. Temperature

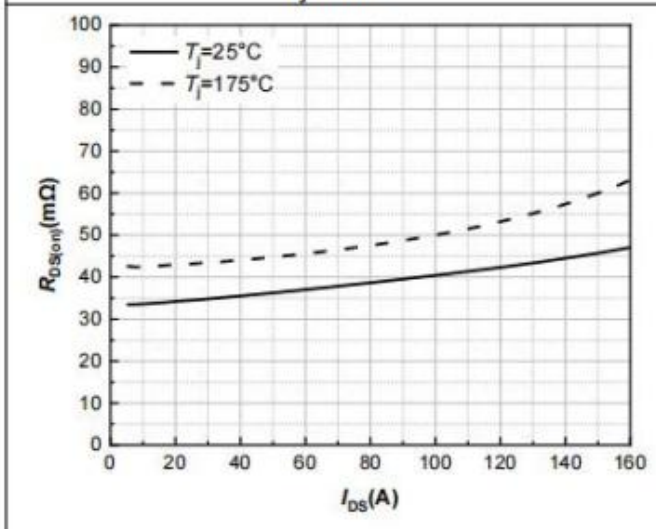

Figure 5. On-Resistance vs. Drain Current For Various Temperatures

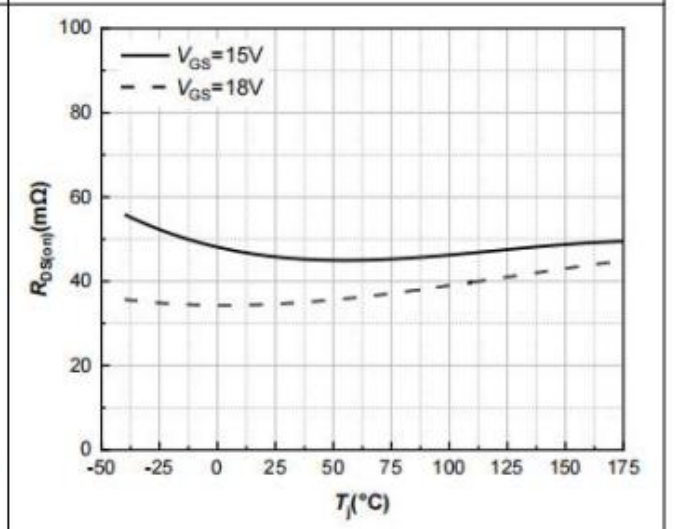

Figure 6. On-Resistance vs. Temperature For Various Gate Voltage

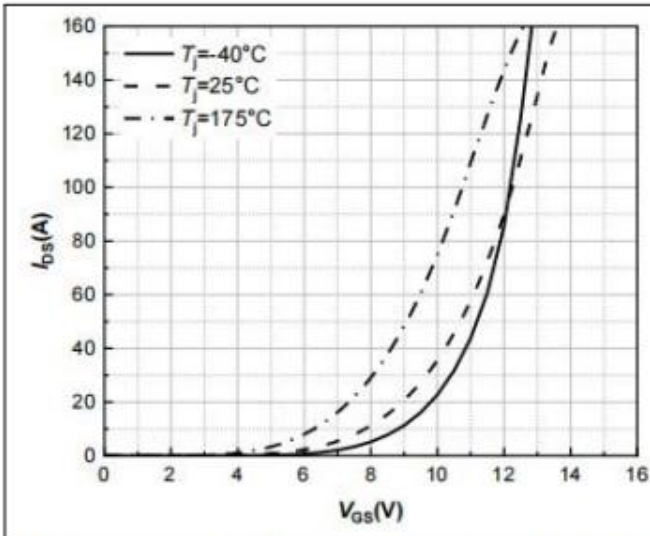

Figure 7. Transfer Characteristic for Various Junction Temperatures $V_{DS}=20V$

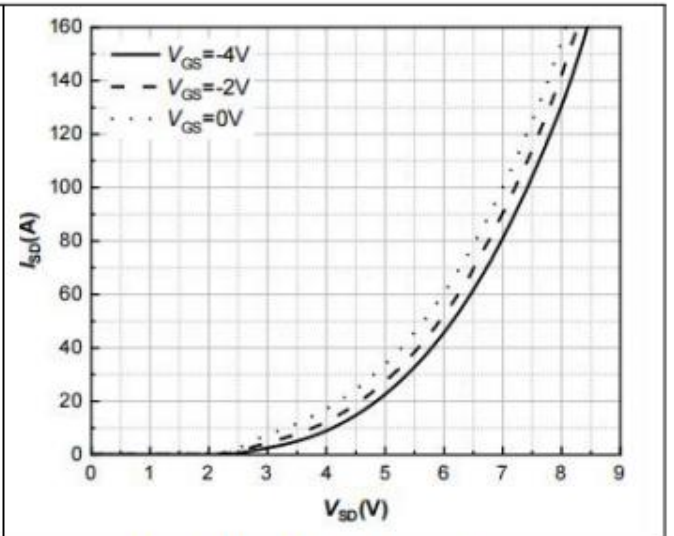

Figure 8. Body Diode Characteristic $T_J=-40^{\circ}C$

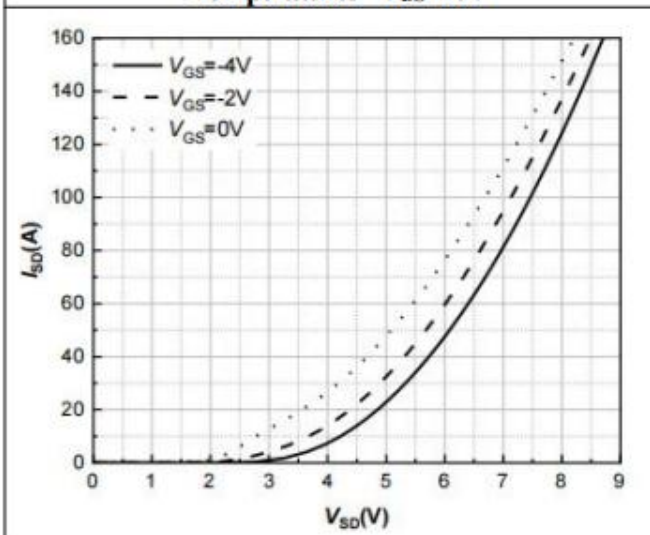

Figure 9. Body Diode Characteristic $T_J=25^{\circ}C$

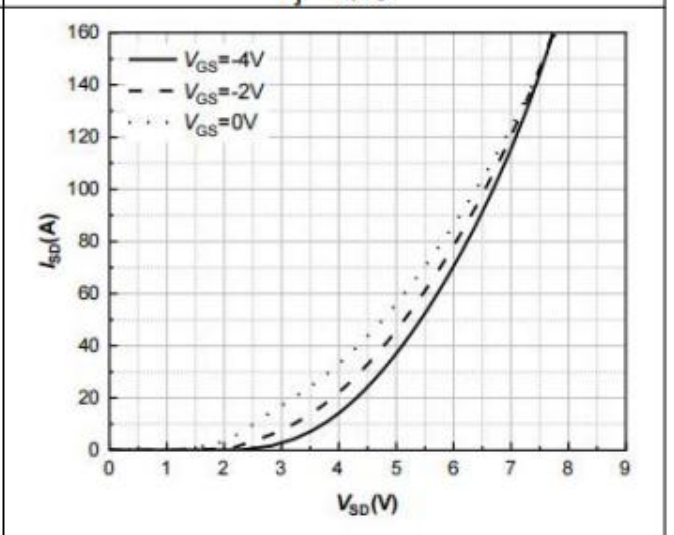

Figure 10. Body Diode Characteristic $T_J=175^{\circ}C$

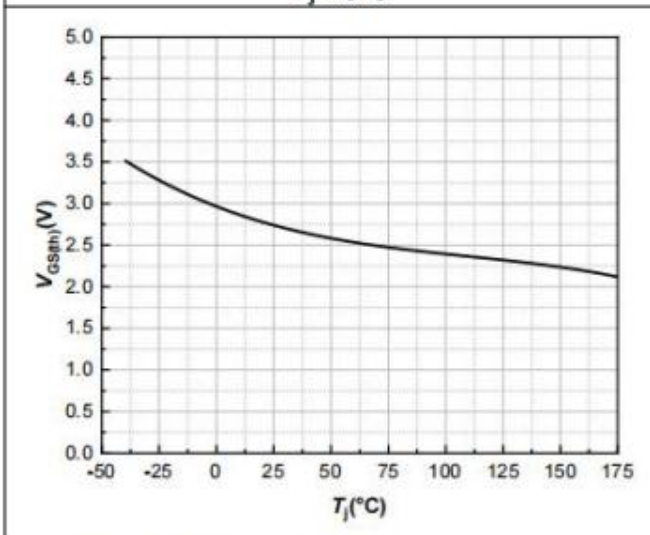

Figure 11. Threshold Voltage vs. Temperature

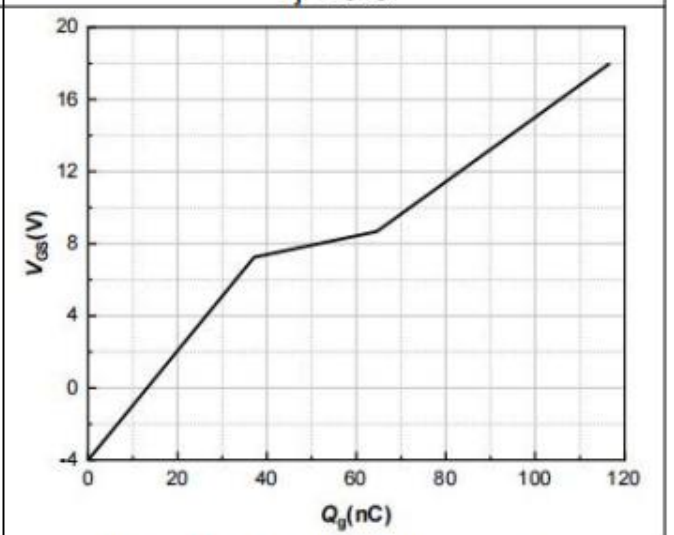

Figure 12. Gate Charge Characteristics

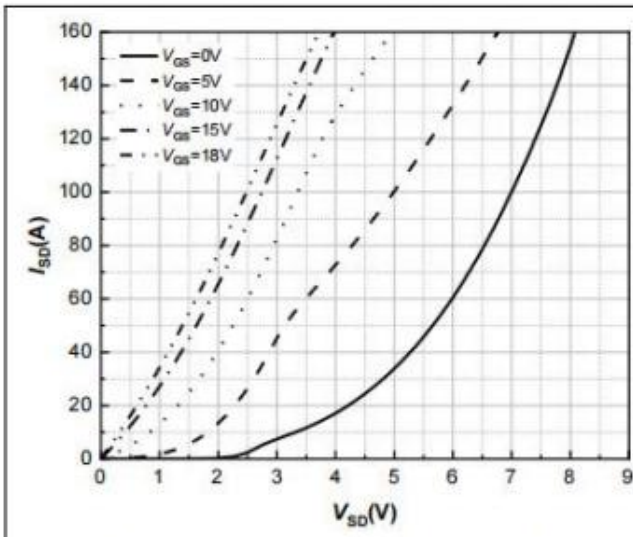

Figure 13. 3rd Quadrant Characteristic
 $T_j = -40^\circ\text{C}$

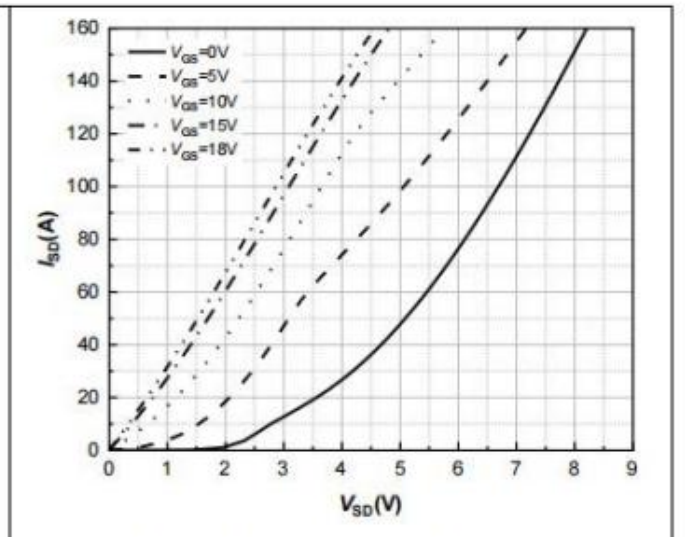

Figure 14. 3rd Quadrant Characteristic
 $T_j = 25^\circ\text{C}$

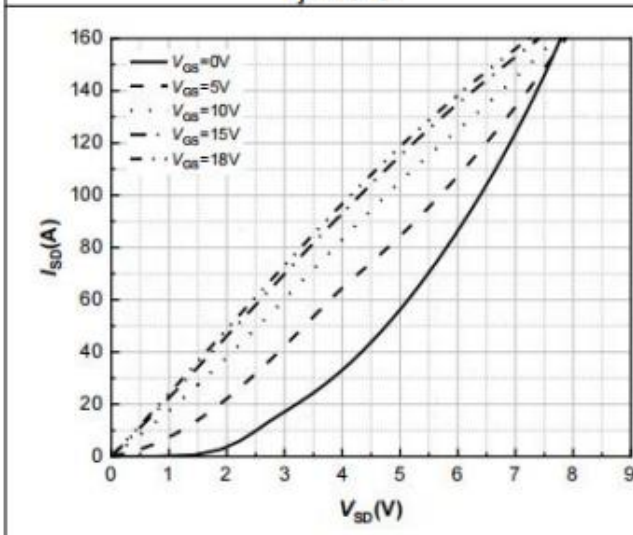

Figure 15. 3rd Quadrant Characteristic
 $T_j = 175^\circ\text{C}$

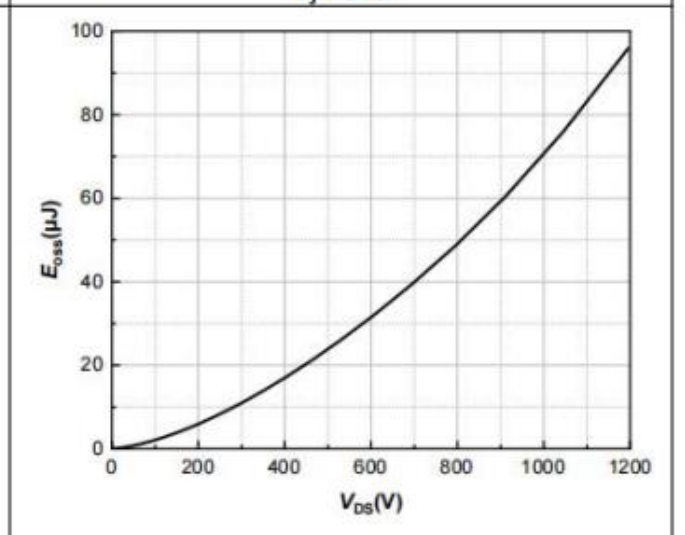

Figure 16. Output Capacitor Stored Energy

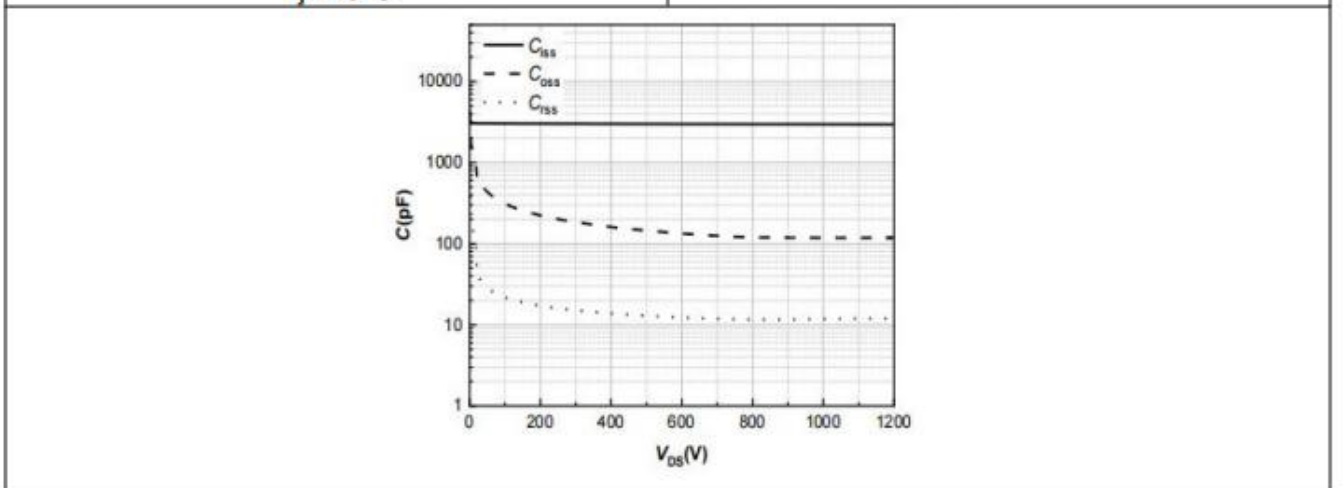
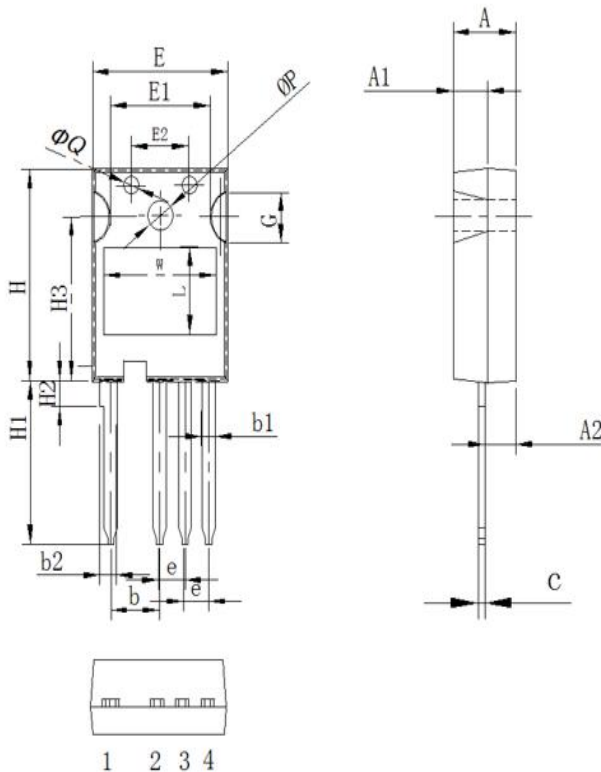

Figure 17. Capacitances vs. Drain-Source

Package Information

TO-247-4L PACKAGE

基本尺寸



Symbol	单位 mm		
	Min	Nom	Max
A	4.8	5.00	5.20
A1	2.8	3.0	3.2
A2	2.20	2.40	2.60
b	4.85	5.05	5.25
b1	1.15	1.25	1.35
b2	2.30	2.50	2.70
c	0.50	0.60	0.70
e	2.35	2.55	2.75
E	15.5	15.7	15.9
E1	10.5	10.7	10.9
E2	7.4	7.6	7.8
G	4.8	5.0	5.2
H	22.4	22.6	22.8
H1	17.5	18.0	18.5
H2	2.42	2.62	2.82
H3	16.17	16.37	16.57
ΦP	3.40	3.60	3.8
ΦQ	2.3	2.5	2.7
W	11.8	12	12.2
L	8.3	8.5	8.7

Notice

Thunder Microelectronics Incorporated Limited reserves the right to make changes without further notice to any products or specifications herein. When use the product, be sure to obtain the latest specification.

Thunder Microelectronics Incorporated Limited does not assume any liability arising out of the application or any product described herein. When using Thunder Microelectronics Incorporated Limited products in your equipment, you are requested to take adequate safety measures to prevent the equipment from causing a physical injury ,fire or other problem if any of the products become faulty.

-Headquarters

WuXi Thunder Microelectronics Incorporated Limited

Building E1-901, No.200 LingHu Road, XinWu district,WuXi,China 214135

Tel:+86-510-85160109 Fax:+86-510-85160109