

## Silicon N-Channel Planar Power MOSFET

### Description

The TH44N25PK utilizes the latest processing techniques to achieve low on-resistance per silicon area. Additional features of this MOSFET are 150°C operating junction temperature and high repetitive peak current capability. These features combine to make this MOSFET a highly efficient, robust and reliable device for PDP driving applications. It can be used in a wide variety of applications.

### General Features

- $V_{DS}=250V, I_D=44A$
- Low ON Resistance,  $R_{DS(ON)}=55m\Omega @ V_{GS}=10V, I_D=22A$
- Low reverse transfer capacitance
- Low Qg for fast response
- Short fall & rise times for fast switching
- 100% single pulse avalanche energy Test

### Application

- Power switching application
- Digital amplifier
- Adapter and charger

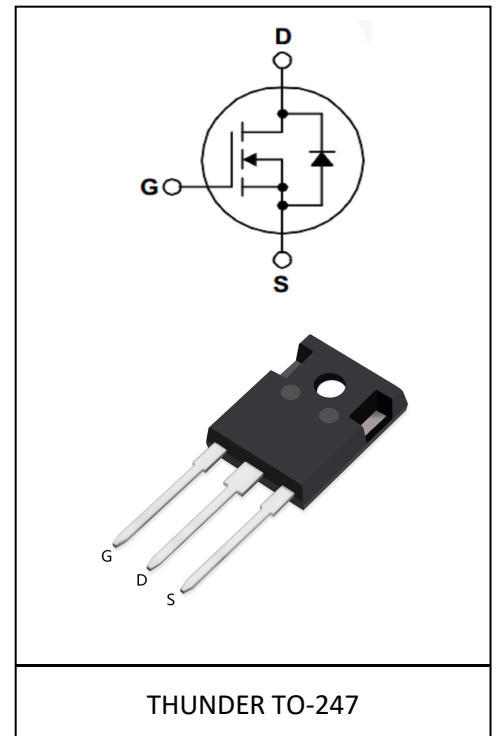

### Product Summary

$V_{DS}$	250V
$R_{DS(on)}$	55m $\Omega$
$I_D$	44A

### Absolute Maximum Ratings

Parameter	Symbol	Value	Unit
Drain-source voltage	$V_{DS}$	250	V
Continuous drain current $T_C = 25^\circ C$ (Silicon limit)	$I_D$	44	A
Pulsed drain current ( $T_C = 25^\circ C$ , $t_p$ limited by $T_{jmax}$ )	$I_{DM}$	176	A
Avalanche energy, single pulse ( $L=10mH$ , $R_g=25\Omega$ )	$E_{AS}$	1124	mJ
Gate-Source voltage	$V_{GS}$	$\pm 30$	V
Power dissipation ( $T_C = 25^\circ C$ )	$P_D$	313	W
Operating junction and storage temperature	$T_j, T_{stg}$	-55...+150	$^\circ C$

### Thermal Resistance

Parameter	Symbol	Max	Unit
Thermal resistance, junction – case.	$R_{thJC}$	0.4	°C/W
Thermal resistance, junction – ambient(min. footprint)	$R_{thJA}$	62.5	

### Electrical Characteristic (at $T_j = 25\text{ }^\circ\text{C}$ , unless otherwise specified)

Parameter	Symbol	Value			Unit	Test Condition
		min.	typ.	max.		

### Static Characteristic

Drain-source breakdown voltage	$BV_{DSS}$	250	-	-	V	$V_{GS}=0V, I_D=250\mu A$
Gate threshold voltage	$V_{GS(th)}$	2.0	-	4.0	V	$V_{DS}=V_{GS}, I_D=250\mu A$
Zero gate voltage drain current	$I_{DSS}$	-	-	1	$\mu A$	$V_{DS}=250V, V_{GS}=0V$ $T_j=25\text{ }^\circ\text{C}$
		-	-	10	$\mu A$	$V_{DS}=200V, V_{GS}=0V$ $T_j=125\text{ }^\circ\text{C}$
Gate-source leakage current	$I_{GSS}$	-	-	$\pm 100$	nA	$V_{GS}=\pm 30V, V_{DS}=0V$
Drain-source on-state resistance	$R_{DS(on)}$	-	55	66	m $\Omega$	$V_{GS}=10V, I_D=22A$
Transconductance	$g_{fs}$	-	32	-	S	$V_{DS}=40V, I_D=22A$

### Dynamic Characteristic

Input Capacitance	$C_{iss}$	-	3877	-	pF	$V_{GS}=0V, V_{DS}=25V,$ $f=1MHz$
Output Capacitance	$C_{oss}$	-	395	-		
Reverse Transfer Capacitance	$C_{rss}$	-	6.8	-		
Gate Total Charge	$Q_g$	-	45	-	nC	$V_{GS}=10V, V_{DS}=200V,$ $I_D=44A$
Gate-Source charge	$Q_{gs}$	-	17	-		
Gate-Drain charge	$Q_{gd}$	-	25	-		
Turn-on delay time	$t_{d(on)}$	-	53	-	ns	$V_{DD}=125V, I_D=44A,$ $R_G=25\Omega$
Rise time	$t_r$	-	398	-		
Turn-off delay time	$t_{d(off)}$	-	86	-		
Fall time	$t_f$	-	116	-		
Gate resistance	$R_G$	-	1	-	$\Omega$	$V_{GS}=0V, V_{DS}=0V,$ $f=1MHz$

### Body Diode Characteristic

Parameter	Symbol	Value			Unit	Test Condition
		min.	typ.	max.		
Body Diode Forward Voltage	$V_{SD}$	-	-	1.4	V	$V_{GS}=0V, I_{DS}=44A$
Body Diode Continuous Forward Current	$I_S$	-	-	44	A	$T_C=25^\circ C$
Body Diode Reverse Recovery Time	$t_{rr}$	-	196	-	ns	$T_C=25^\circ C, I_S=44A,$ $di/dt=100A/us$
Body Diode Reverse Recovery Charge	$Q_{rr}$	-	1.5	-	$\mu C$	

### Typical Performance Characteristics

Fig 1: On-Region Characteristics

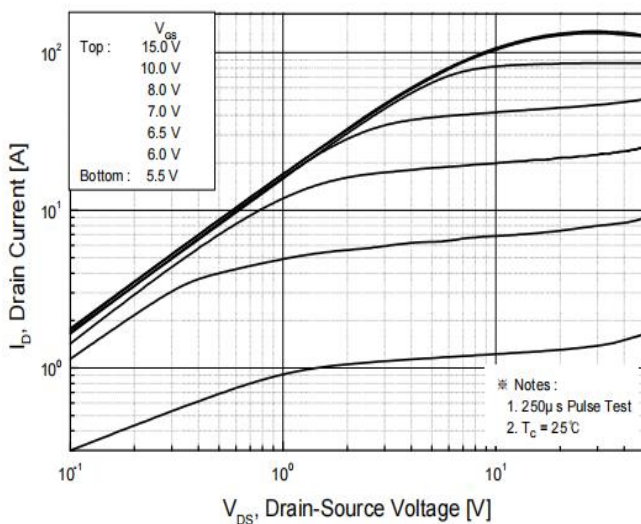

Fig 2: Transfer Characteristics

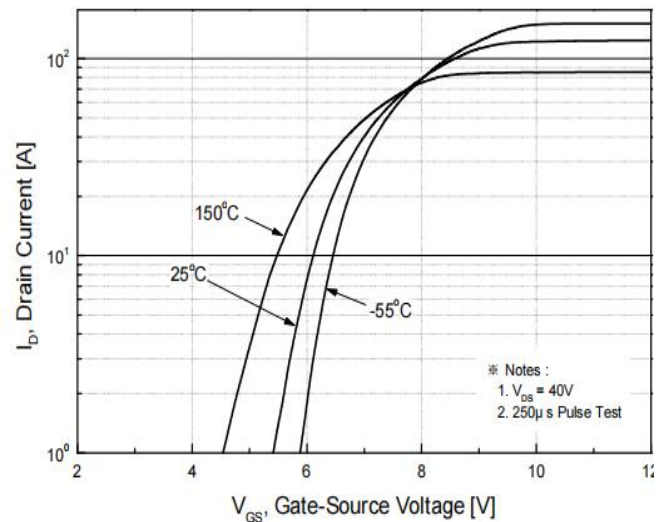

Fig 3: Typical Output Characteristics

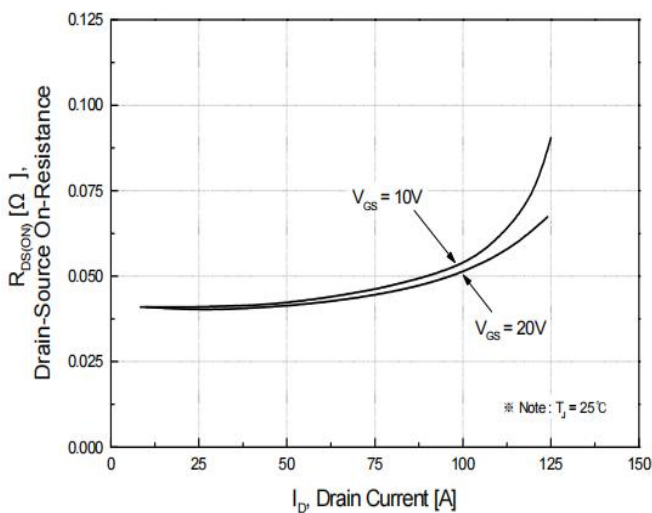

Fig 4: Body Diode Forward Voltage Variation vs. Source Current and Temperature

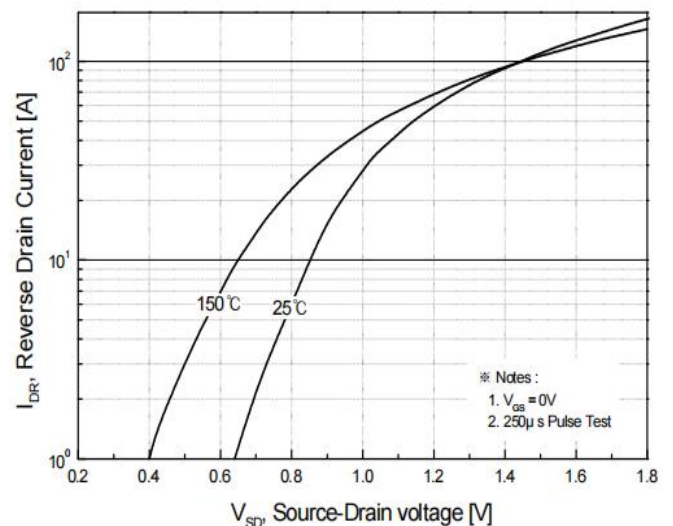

Fig 5: Gate Charge Characteristics

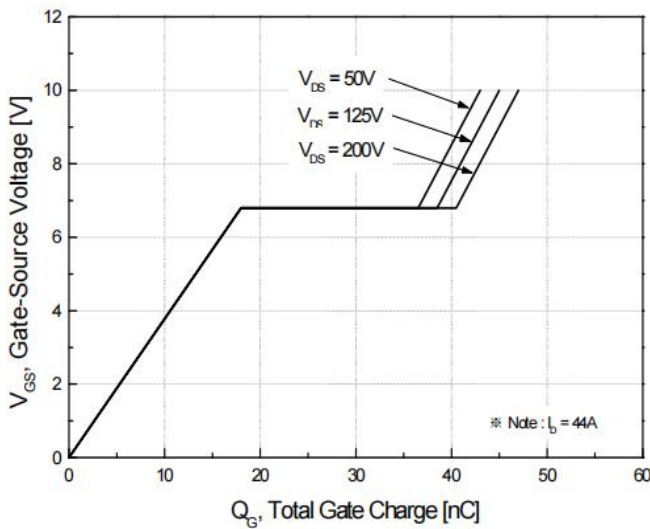

Fig 7: Power Dissipation

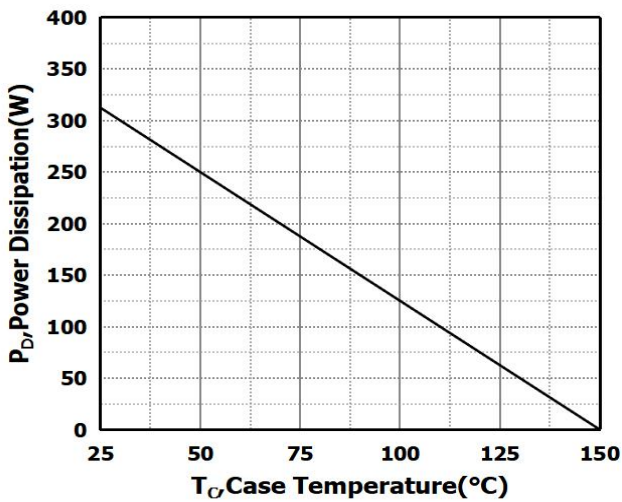

Fig 9: On-Resistance Variation vs. Temperature

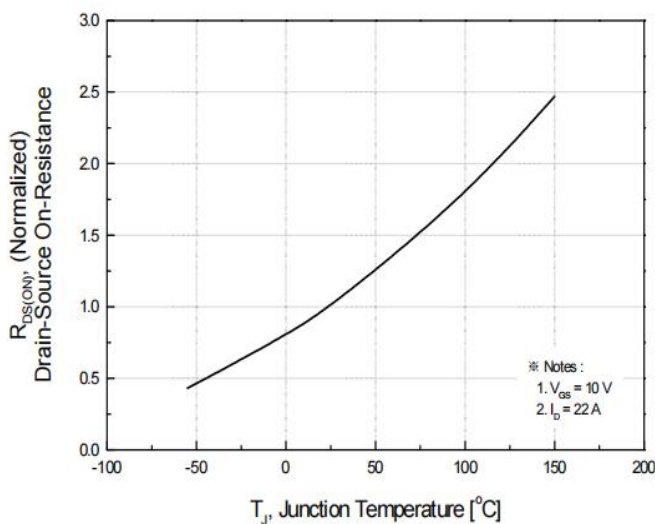

Fig 6: Capacitance Characteristics

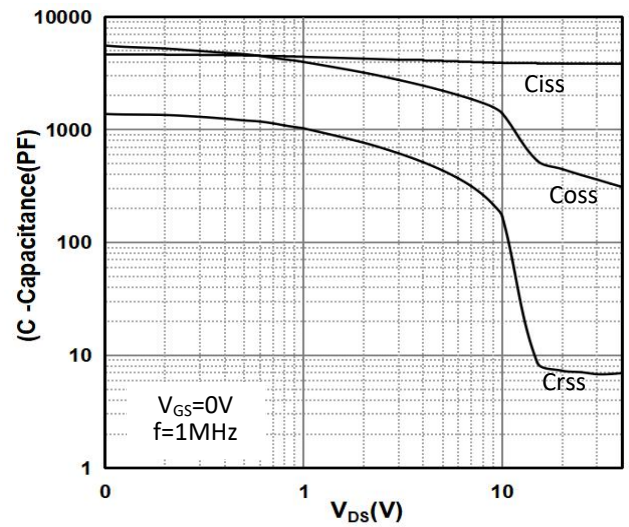

Fig 8: Drain Current Derating

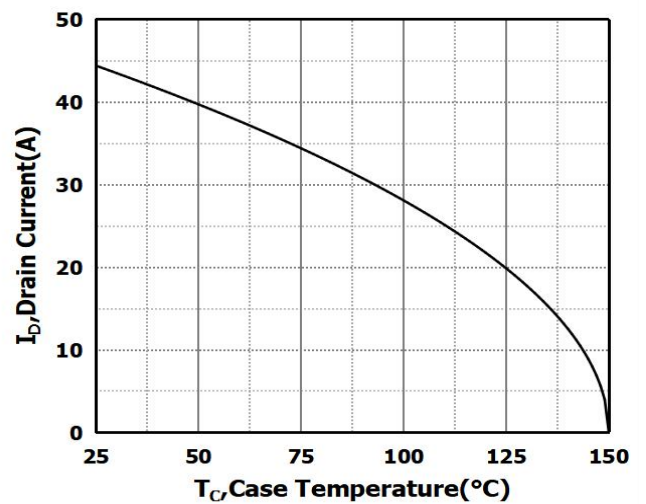

Fig 10: Safe Operating Area

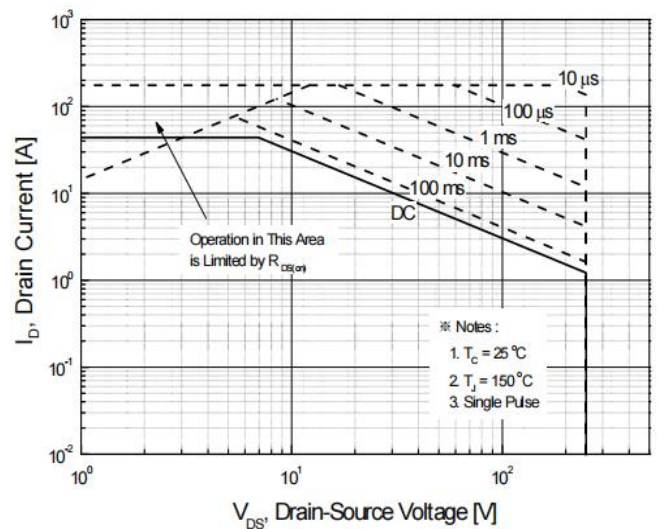
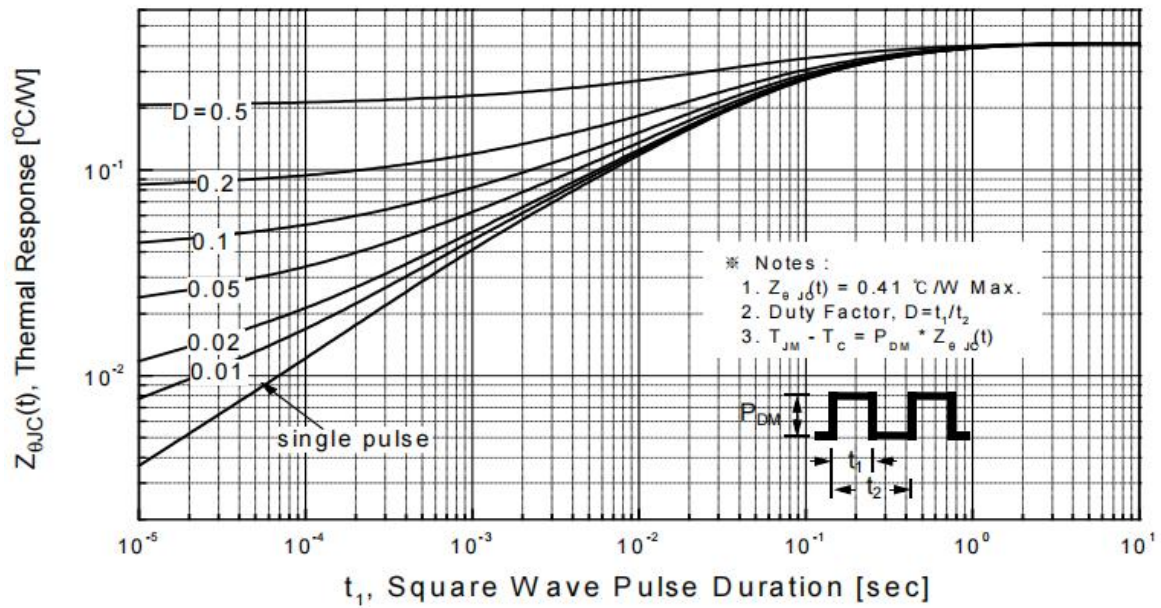
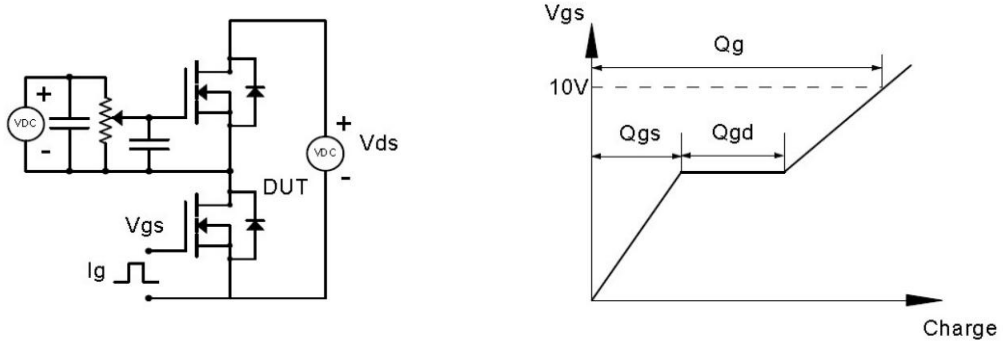

Fig 11: Transient Thermal Response Curve



## Test Circuit & Waveform

Gate Charge Test Circuit & Waveform



Resistive Switching Test Circuit & Waveforms

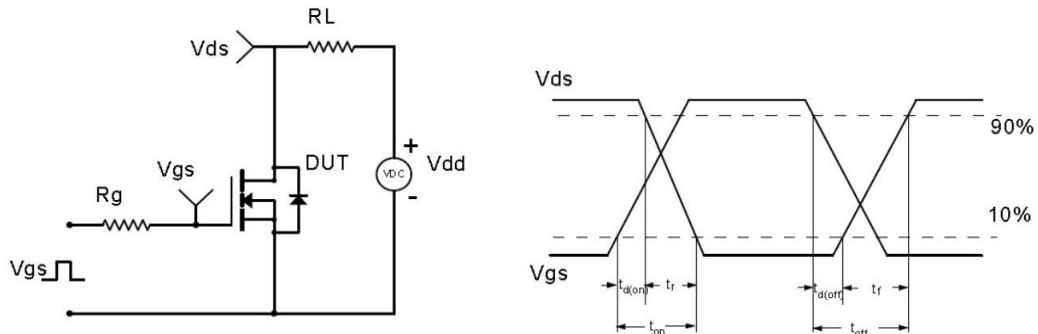

Unclamped Inductive Switching (UIS) Test Circuit & Waveforms

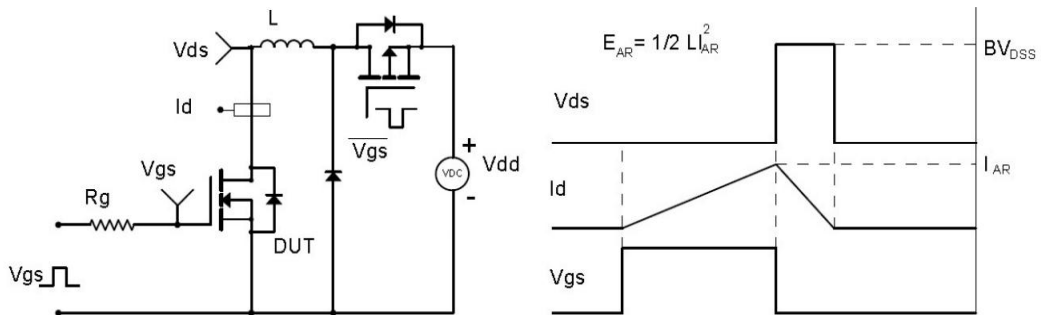

Diode Recovery Test Circuit & Waveforms

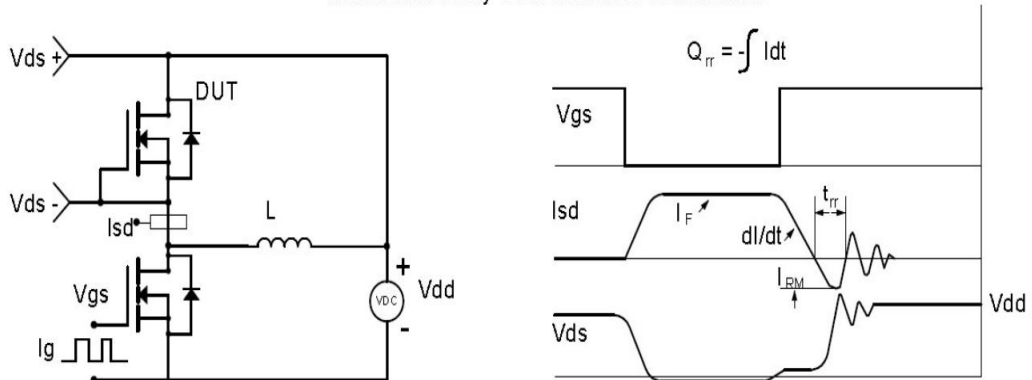

## Package Information

### TO-247 PACKAGE

### 基本尺寸

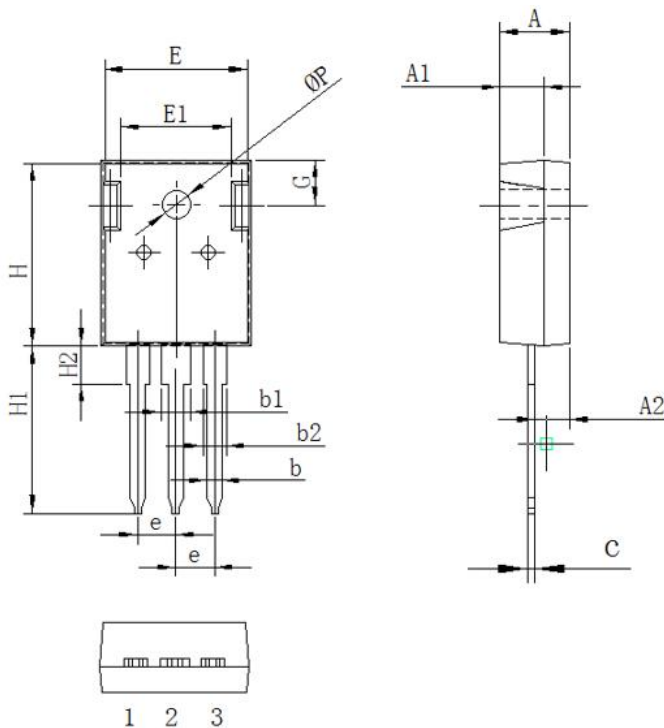

Symbol	单位 mm		
	Min	Nom	Max
A	4.8	5.00	5.20
A1	3.3	3.5	3.7
A2	2.20	2.40	2.60
b	1.00	1.2	1.40
b1	2.90	3.10	3.30
b2	1.90	2.10	2.30
c	0.50	0.60	0.70
e	5.25	5.45	5.65
E	15.2	15.7	16.2
E1	10.2	10.7	11.2
H	20.8	21	21.2
H1	19.5	20.0	20.5
H2	4.00	4.20	4.40
G	5.60	5.80	600
ΦP	3.50	3.70	3.90

## Notice

Thunder Microelectronics Incorporated Limited reserves the right to make changes without further notice to any products or specifications herein. When use the product, be sure to obtain the latest specification.

Thunder Microelectronics Incorporated Limited does not assume any liability arising out of the application or any product described herein. When using Thunder Microelectronics Incorporated Limited products in your equipment, you are requested to take adequate safety measures to prevent the equipment from causing a physical injury ,fire or other problem if any of the products become faulty.

### -Headquarters

WuXi Thunder Microelectronics Incorporated Limited  
 Building E1-901, No.200 LingHu Road, XinWu district,WuXi,China 214135  
 Tel:+86-510-85160109 Fax:+86-510-85160109