

Silicon N-Channel Planar Power MOSFET

Description

The TH28N50PU utilizes the latest processing techniques to achieve low on-resistance per silicon area. Additional features of this MOSFET are 150°C operating junction temperature and high repetitive peak current capability. These features combine to make this MOSFET a highly efficient, robust and reliable device for PDP driving applications. It can be used in a wide variety of applications.

General Features

- $V_{DS}=500V, I_D=28A$
- Low ON Resistance, $R_{DS(ON)}=130m\Omega @ V_{GS}=10V, I_D=14A$
- Low reverse transfer capacitance
- Low Qg for fast response
- Short fall & rise times for fast switching
- 100% single pulse avalanche energy Test

Application

- Power switching application
- Digital amplifier
- Adapter and charger

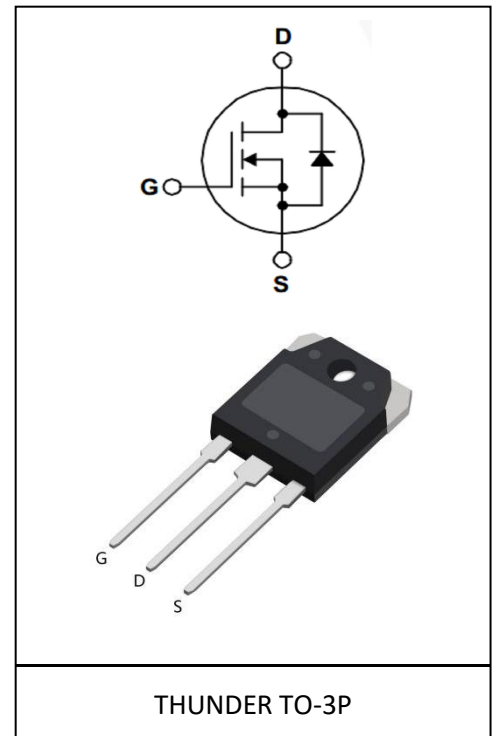

Product Summary

V_{DS}	500V
$R_{DS(on)}$	130mΩ
I_D	28A

Absolute Maximum Ratings

Parameter	Symbol	Value	Unit
Drain-source voltage	V_{DS}	500	V
Continuous drain current $T_C = 25^\circ C$ (Silicon limit)	I_D	28	A
Pulsed drain current ($T_C = 25^\circ C$, t_p limited by T_{jmax})	I_{DM}	112	A
Avalanche energy, single pulse ($L=10mH, R_g=25\Omega$)	E_{AS}	2680	mJ
Gate-Source voltage	V_{GS}	±30	V
Power dissipation ($T_C = 25^\circ C$)	P_D	313	W
Operating junction and storage temperature	T_j, T_{stg}	-55...+150	°C

Thermal Resistance

Parameter	Symbol	Max	Unit
Thermal resistance, junction – case.	R_{thJC}	0.4	°C/W
Thermal resistance, junction – ambient(min. footprint)	R_{thJA}	40	

Electrical Characteristic (at $T_j = 25\text{ }^\circ\text{C}$, unless otherwise specified)

Parameter	Symbol	Value			Unit	Test Condition
		min.	typ.	max.		

Static Characteristic

Drain-source breakdown voltage	BV_{DSS}	500	-	-	V	$V_{GS}=0V, I_D=250\mu A$
Gate threshold voltage	$V_{GS(th)}$	2.0	-	4.0	V	$V_{DS}=V_{GS}, I_D=250\mu A$
Zero gate voltage drain current	I_{DSS}	-	-	1	μA	$V_{DS}=500V, V_{GS}=0V$ $T_j=25^\circ C$
		-	-	10	μA	$V_{DS}=400V, V_{GS}=0V$ $T_j=125^\circ C$
Gate-source leakage current	I_{GSS}	-	-	± 100	nA	$V_{GS}=\pm 30V, V_{DS}=0V$
Drain-source on-state resistance	$R_{DS(on)}$	-	130	153	m Ω	$V_{GS}=10V, I_D=14A$
Transconductance	g_{fs}	-	28	-	S	$V_{DS}=20V, I_D=14A$

Dynamic Characteristic

Input Capacitance	C_{iss}	-	5680	-	pF	$V_{GS}=0V, V_{DS}=25V,$ $f=1MHz$
Output Capacitance	C_{oss}	-	420	-		
Reverse Transfer Capacitance	C_{rss}	-	4.0	-		
Gate Total Charge	Q_g	-	65	-	nC	$V_{GS}=10V, V_{DS}=400V,$ $I_D=28A$
Gate-Source charge	Q_{gs}	-	18	-		
Gate-Drain charge	Q_{gd}	-	26	-		
Turn-on delay time	$t_{d(on)}$	-	44	-	ns	$V_{DD}=250V, I_D=28A,$ $R_G=25\Omega$
Rise time	t_r	-	105	-		
Turn-off delay time	$t_{d(off)}$	-	155	-		
Fall time	t_f	-	92	-		
Gate resistance	R_G	-	0.4	-	Ω	$V_{GS}=0V, V_{DS}=0V,$ $f=1MHz$

Body Diode Characteristic

Parameter	Symbol	Value			Unit	Test Condition
		min.	typ.	max.		
Body Diode Forward Voltage	V_{SD}	-	-	1.4	V	$V_{GS}=0V, I_{DS}=28A$
Body Diode Continuous Forward Current	I_S	-	-	28	A	$T_C=25^\circ C$
Body Diode Reverse Recovery Time	t_{rr}	-	540	-	ns	$T_C=25^\circ C, I_S=28A,$ $di/dt=100A/us$
Body Diode Reverse Recovery Charge	Q_{rr}	-	8.0	-	μC	

Typical Performance Characteristics

Fig 1: Output Characteristics

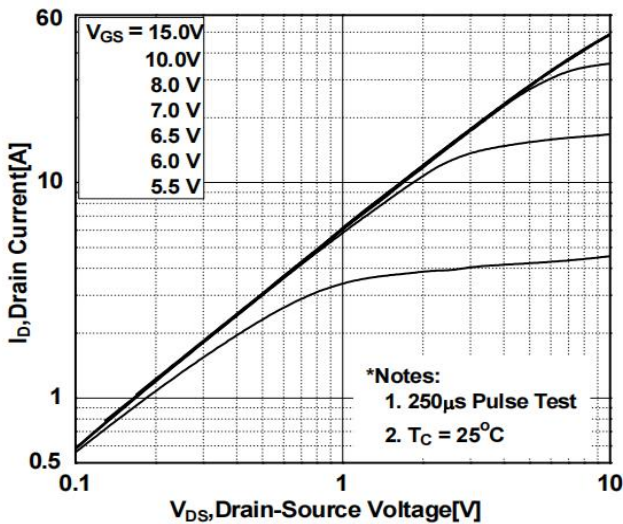

Fig 2: Transfer Characteristics

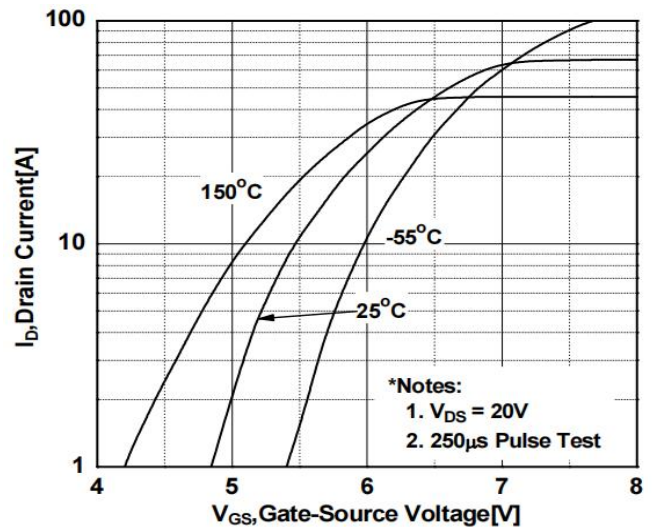

Fig 3: $R_{DS(on)}$ vs Drain Current and Gate Voltage

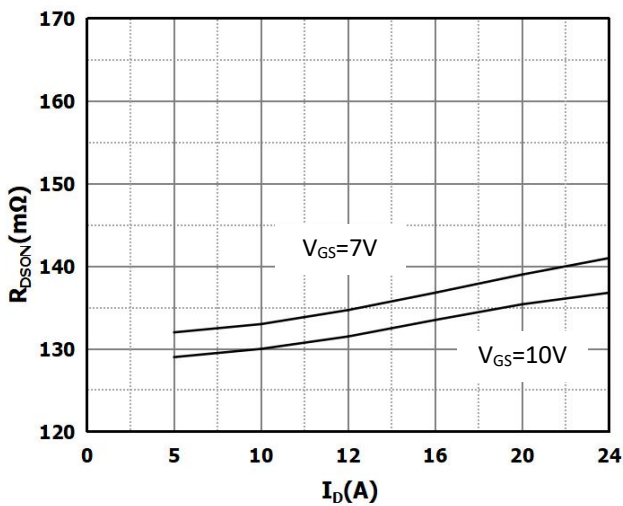

Fig 4: $R_{DS(on)}$ vs Gate Voltage

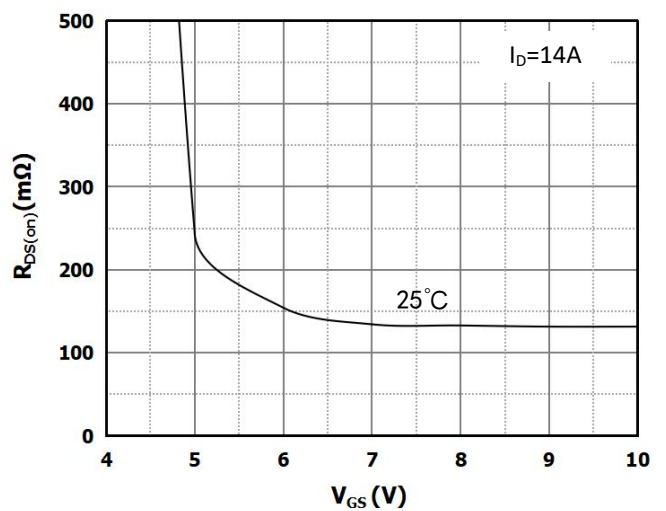

Fig 5: Rds(on) vs. Temperature

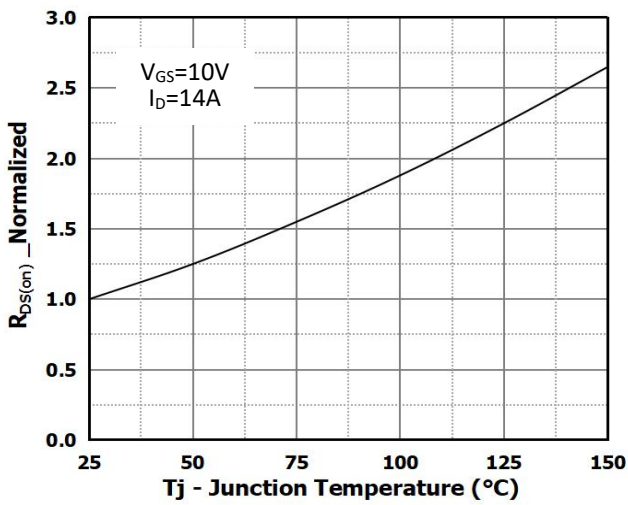

Fig 6: Capacitance Characteristics

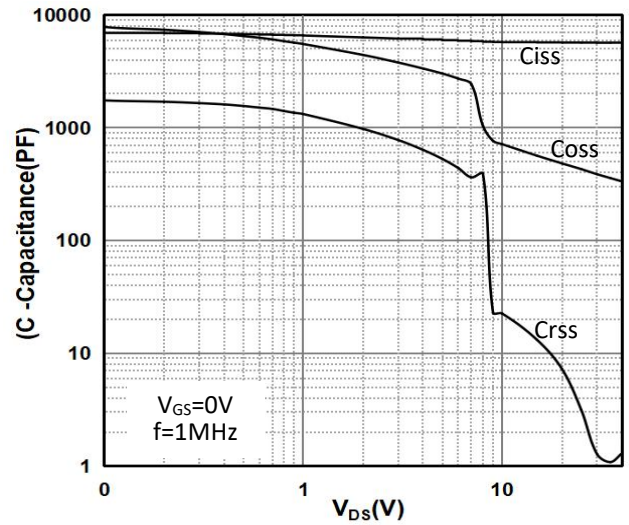

Fig 7: Gate Charge Characteristics

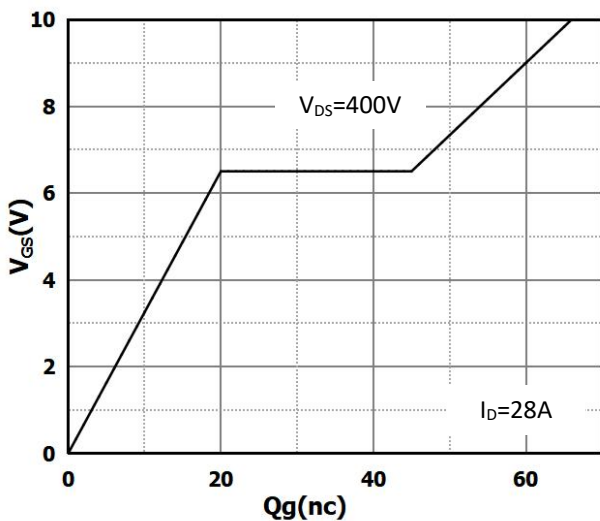

Fig 8: Body-diode Forward Characteristics

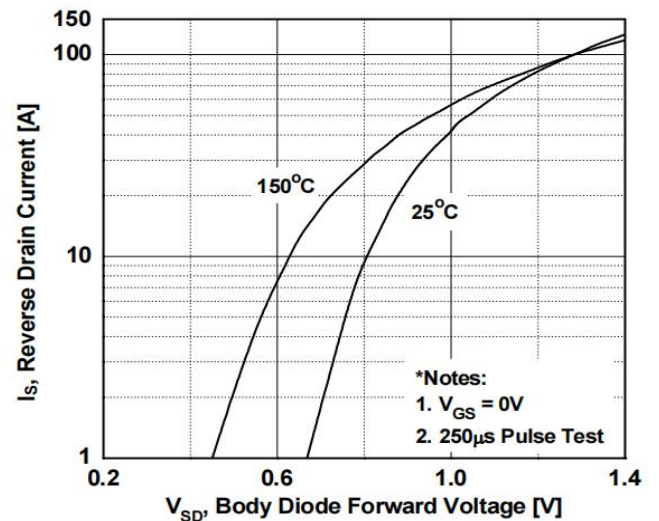

Fig 9: Power Dissipation

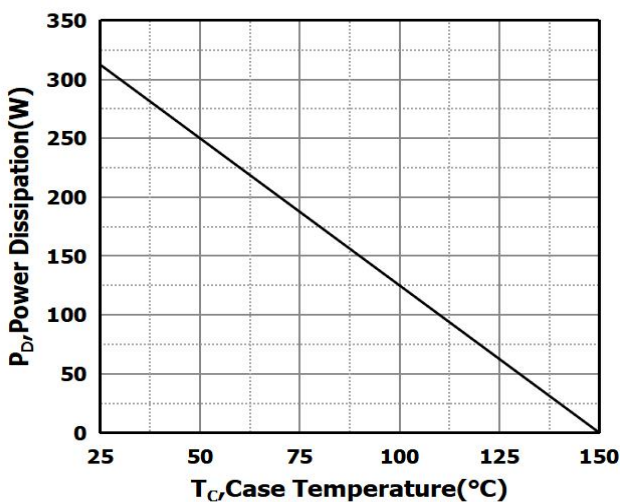

Fig 10: Drain Current Derating

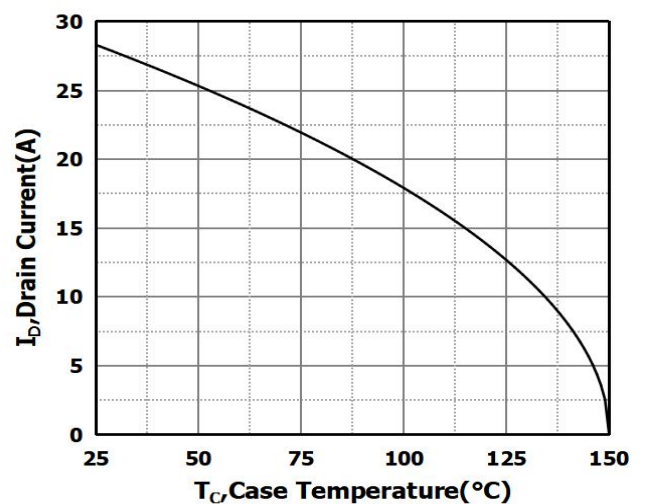

Fig 11: Safe Operating Area

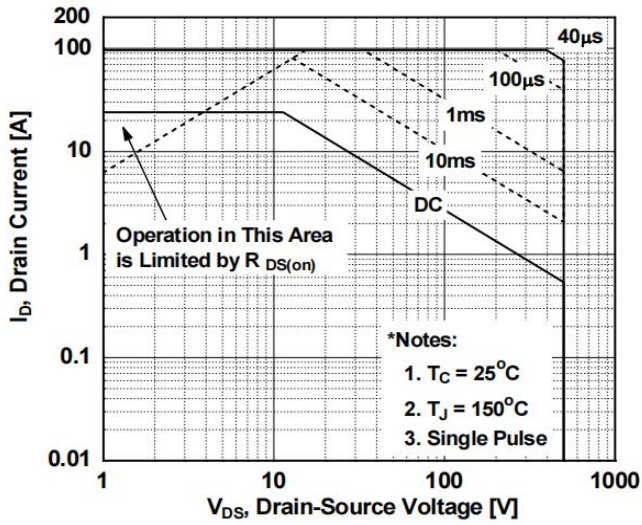
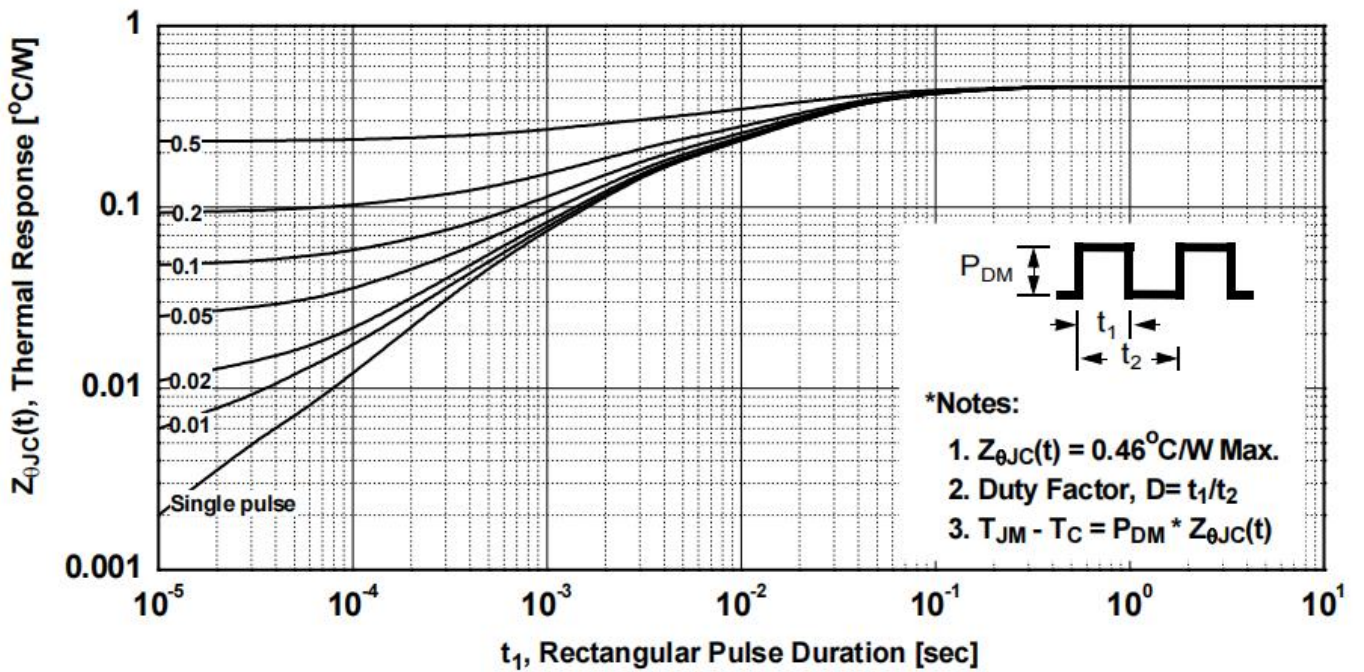
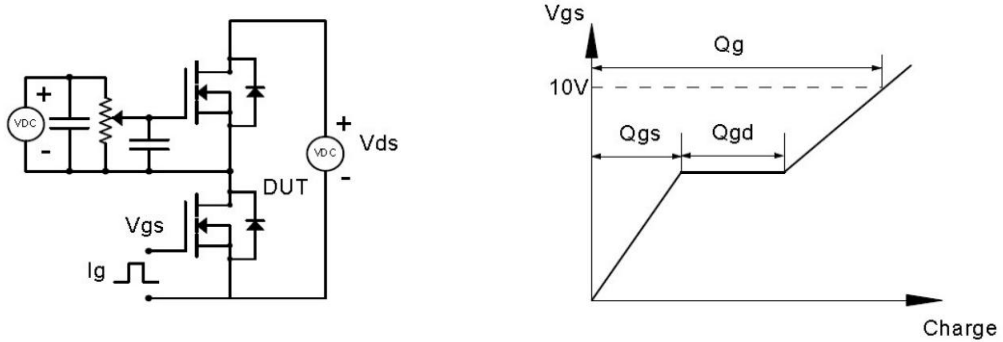

Fig 12: Max. Transient Thermal Impedance



Test Circuit & Waveform

Gate Charge Test Circuit & Waveform



Resistive Switching Test Circuit & Waveforms

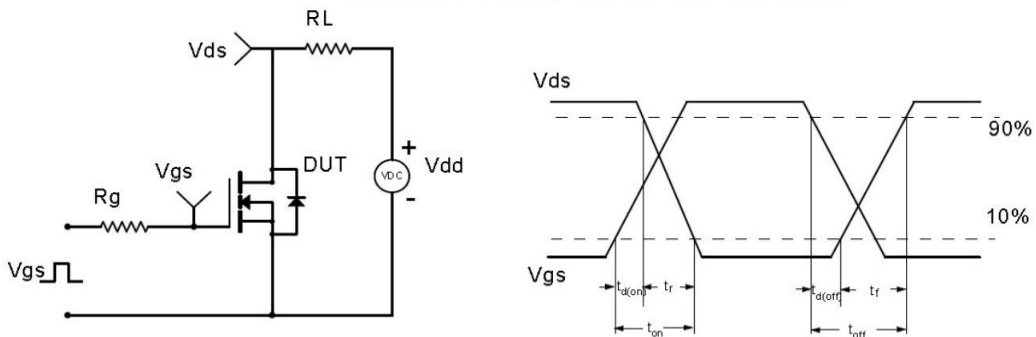

Unclamped Inductive Switching (UIS) Test Circuit & Waveforms

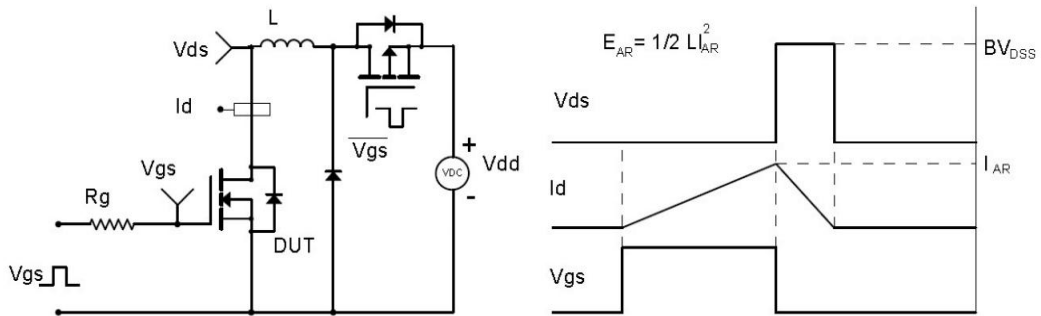

Diode Recovery Test Circuit & Waveforms

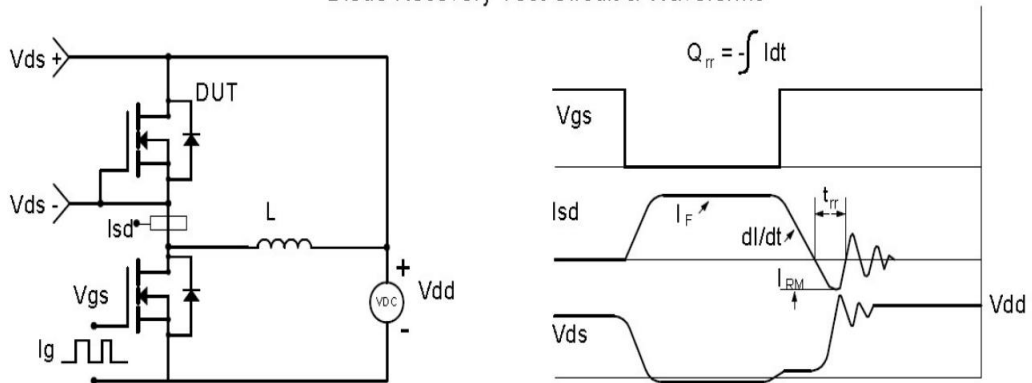

Package Information

TO-3P PACKAGE

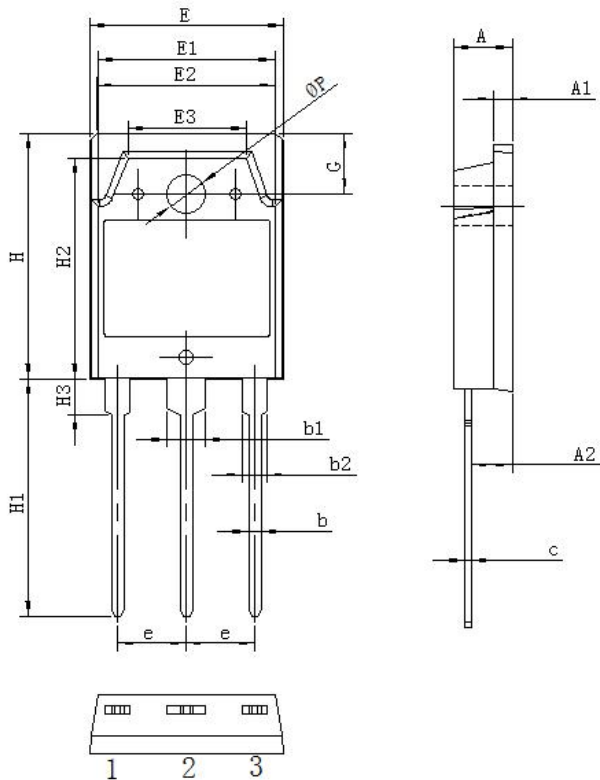

Symbol	单位 mm		
	Min	Nom	Max
A	4.60	4.80	5.00
A1	1.3	1.5	1.7
A2	1.20	1.40	1.60
b	0.80	1.0	1.20
b1	2.90	3.10	3.30
b2	1.90	2.10	2.30
c	0.50	0.60	0.70
e	5.25	5.45	5.65
E	15.2	15.6	16.0
E1	13.2	13.4	13.6
E2	13.1	13.3	13.5
E3	9.1	9.3	9.5
H	19.8	20.0	20.2
H1	20.1	20.3	20.5
H2	18.5	18.7	18.9
H3	3.2	3.5	3.8
G	4.8	5.0	5.2
ΦP	3.00	3.20	3.40

Notice

Thunder Microelectronics Incorporated Limited reserves the right to make changes without further notice to any products or specifications herein. When use the product, be sure to obtain the latest specification.

Thunder Microelectronics Incorporated Limited does not assume any liability arising out of the application or any product described herein. When using Thunder Microelectronics Incorporated Limited products in your equipment, you are requested to take adequate safety measures to prevent the equipment from causing a physical injury ,fire or other problem if any of the products become faulty.

-Headquarters

WuXi Thunder Microelectronics Incorporated Limited

Building E1-901, No.200 LingHu Road, XinWu district,WuXi,China 214135

Tel:+86-510-85160109 Fax:+86-510-85160109